

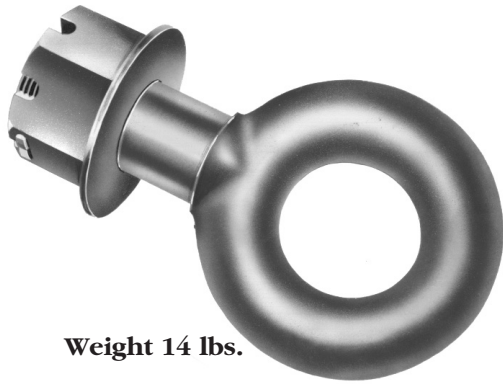

DB-1249-2H

DB-1249-2H SPECIFICATIONS



Weight 14 lbs.



3" I.D. eye forged steel drawbar with induction hardened wear area. 1.63" diameter section with 2" O.D. shank and washer, nut, and cotter pin.

9,000 lbs. Maximum Vertical Load
45,000 lbs. Maximum Gross Trailer Weight

NOTE: When used for hinged tongue trailer applications where maximum vertical load cannot exceed 500 lbs., the maximum gross trailer weight is 85,000 lbs.



WARNING

Maintain sufficient vertical (tongue) load to adequately control the trailer (generally 10% of G.T.W.). But do not exceed the above rated capacities.

TOWING APPLICATIONS:

Trailers, full trailers (including doubles) and equipment designed for over-the-road towing within the stated capacities. For off-road applications, reduce the above capacities by 25%.

MOUNTING:

1. Use a mounting structure of sufficient strength to support the rated capacity of the drawbar in accordance with SAE J849 and SAE J847 respectively.
2. Refer to the drawing on the reverse for proper mounting dimensions (dimensions A, B, and C).
Note: Mounting surface must have an adequate chamfer to clear the drawbar shank fillet so that the drawbar is flush with its mounting surface (see detail on reverse).
3. To mount drawbar to mounting structure, remove cotter pin (D), nut (E) and washer (F) from drawbar (G). Insert drawbar into mounting structure and install washer and nut on drawbar. Torque the nut to 450-650 ft-lbs. and insert cotter pin through castellation in the nut and hole in the drawbar shank. Spread cotter pin.

OPERATION AND MAINTENANCE:

1. Regularly inspect the drawbar for wear and damage. If wear exceeds 1/8" (.125") from the original surface profile, replace the drawbar.
2. Check the mounting nut for proper torque.



WARNING

DURING OPERATION

1. Be sure the drawbar size is compatible with the coupling device on the tow vehicle.
2. Do not damage the coupling components. Be particularly careful during coupling and uncoupling.
3. Inspect the coupling device on the tow vehicle for proper operation. Do not use any coupling device that does not operate properly.
4. Other steps and inspections are also required. consult OSHA and D.O.T. regulations and American Trucking Association for complete coupling and uncoupling procedures. These cover items such as cargo securement, brakes, lights, safety chains and other important requirements.

GENERAL INFORMATION:

1. Do not modify or add to the product.
2. Wear safety goggles during installation and removal.
3. Never strike any part of the item with a steel hammer.
4. Do not weld on this product, other than as directed for installation, without written consent from the factory.



WARNING

This equipment must not be used or maintained in a careless manner.

This product is covered by Holland's Commercial Products Warranty. Holland reserves the right, without giving prior notice, to change specifications and dimensions as designs are altered or improved.

DB-1249-2H

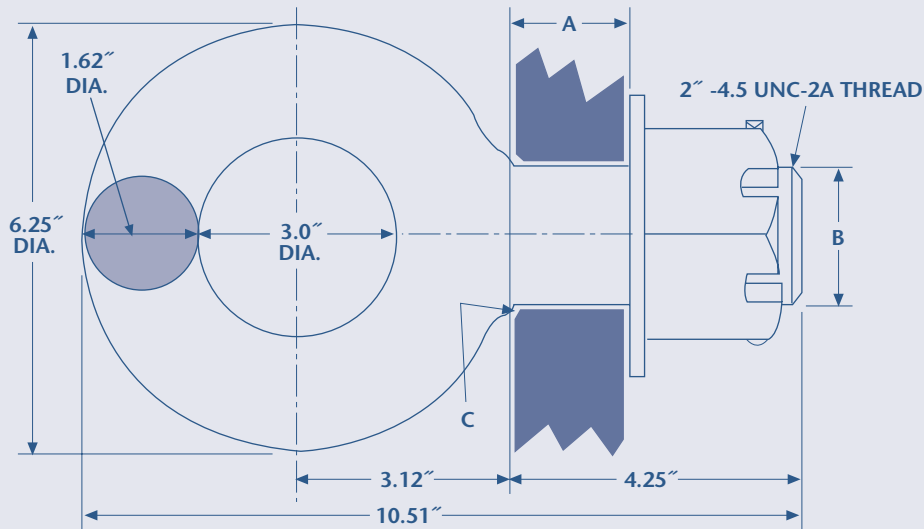

MOUNTING DIMENSIONS

| | | |
|-----------|------------|------------|
| A | Mtg. Width | 1.75" |
| B | Hole Size | 2.03" |
| C* | Chamfer | .15" x 45° |

***Note:** The mounting surface must have an adequate chamfer as shown above so that the drawbar mounts flush with the mounting surface.

ALL DIMENSIONS SHOWN ARE NOMINAL

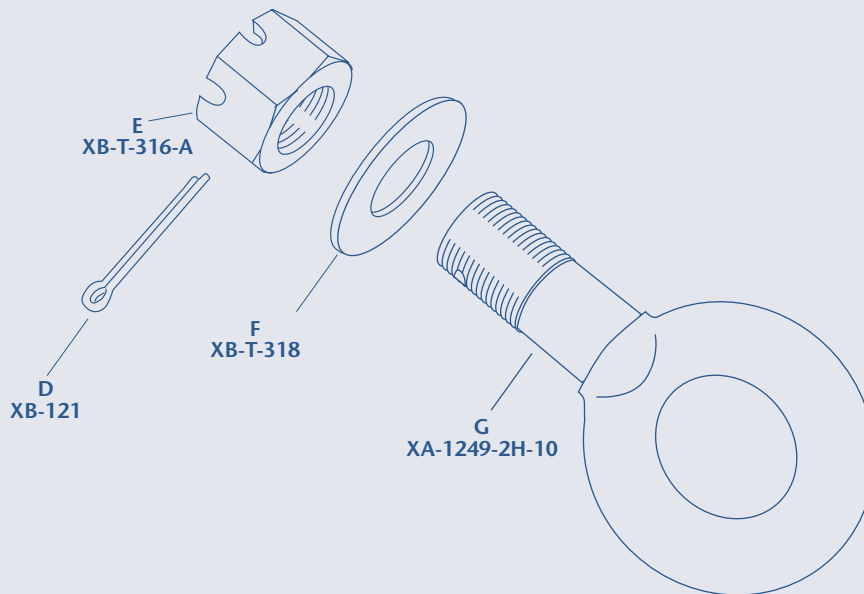

Copyright © April 2001 • The Holland Group, Inc.

Holland Hitch Company Divisions:

Holland, MI
Whitehouse Station, NJ
Denmark, SC
Wylie, TX
Milpitas, CA
Phone: 888-396-6501
Fax: 800-769-3299

Holland Binkley Co.

Warrenton, MO
Phone: 636-456-3455
Fax: 636-456-6792

Holland Binkley Co. Axle Products Division

Delphos, OH
Phone: 419-692-6015
Fax: 419-692-0503

Holland Neway International, Inc.

Muskegon, MI
Phone: 231-773-3271
Fax: 231-766-3893

Holland International, Inc.

Holland, MI
Phone: 616-396-6501
Fax: 616-396-1511

Holland Hitch of Canada, Ltd.

Woodstock, Ontario • Canada
Phone: 519-537-3494
Fax: 800-565-7753

Holland Hitch Western, Ltd.

Surrey, British Columbia • Canada
Phone: 604-574-7491
Fax: 604-574-0244

Holland Equipment, Ltd.

Norwich, Ontario • Canada
Phone: 519-863-3414
Fax: 519-863-2398