

Installation Instructions



BENDIX® BA-922® COMPRESSOR RETROFITS

This instruction sheet includes full installation instructions for all the kits and individual parts required for this retrofit.

The chart below shows the retrofit kits required, and other parts potentially needed, to retrofit a Bendix® BA-922® compressor on DDC® S50 and S60 engines (CNG and Diesel), typically for transit bus applications.

Service Parts/Kits	For Compressed Natural Gas (CNG) Vehicles	For Diesel Vehicles With Rear-mount ECMs	For Diesel Vehicles With Sidemount ECMs
Compressor Fitting Kit 5016660 (this kit)	✓	✓	✓
Coolant Supply and Return Kit 5016661	✓	✓	✓
Coolant Hose Kit 5016662	✓	✗	✗
Rear Support Bracket Kit 5016663	✓	✓	✓
Diesel Fuel Pump Fittings Kit 5016664	✗	✓	✓
Electronic Commutated Motor (ECM) Relocation Kit 5016250	✗	✗	✓
Gasket, air compressor to gear case (DDC PN 8929299)	✓	✓	✓
Rear cover plate (DDC PN 23515940) Rear cover plate gasket (DDC PN 23505248)	✓	✗	✗
Fuel Pump (DDC PN 23532874) Fuel Pump O-ring (DDC PN 23530136) Fuel Line (DDC PN MAHP0109)	✗	✓	✓
Coolant return line (DDC PN 23528004) IMPCO® coolant outlet Tee (DDC PN 23532533)	✓ (May be able to reuse existing line.)	✗	✗
Coolant return line (DDC PN 23526867)	✗	✓ (May be able to reuse existing line.)	✓ (May be able to reuse existing line.)

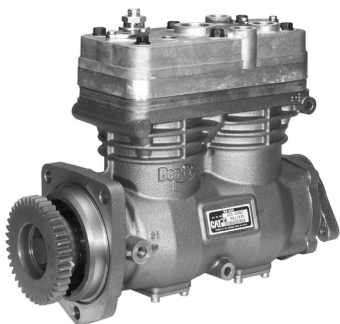

Bendix® BA-922® Compressor

Depending on Vehicle Installation, Some of The Following Items May be Required

Gearcase Power Take Off (PTO) cover plate (DDC PN 23514714)
Gearcase PTO Cover Plate Gasket (DDC PN 8929130)

Compressor Mounting Stud (DDC PN 23517130)

SAE A Flange Gasket for Hydraulic Pump (DDC PN 23516100)
SAE B Flange Gasket for Hydraulic Pump (DDC PN 23516101)

Governor Mounting Bolts M8 - 2.95 in. (75 mm) (Bendix PN 5014067)
Governor Gasket (Bendix PN 236577)
(Remote Governor) - 1/8" NPT Adapter Fitting

KIT CONTENTS

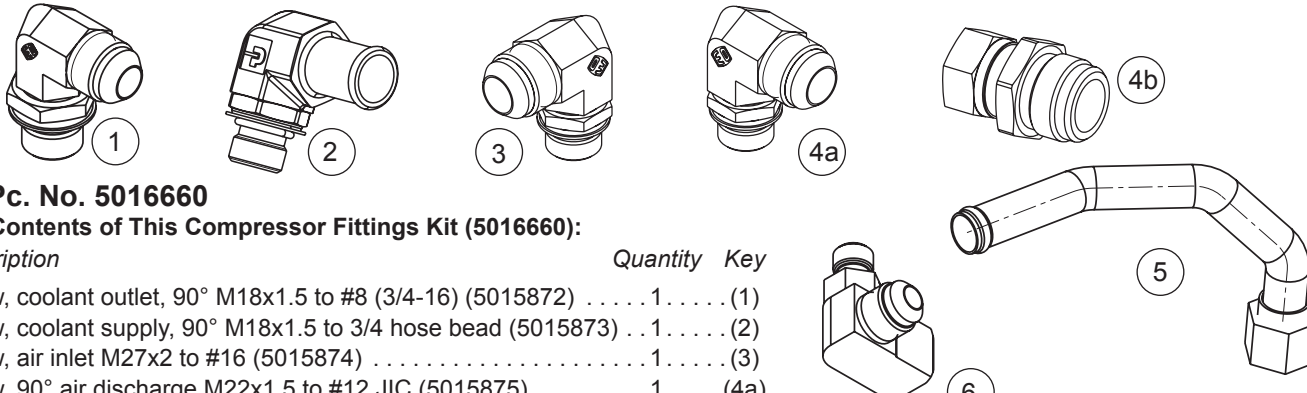

Kit Pc. No. 5016660
The Contents of This Compressor Fittings Kit (5016660):

Description	Quantity	Key
Elbow, coolant outlet, 90° M18x1.5 to #8 (3/4-16) (5015872)	1	(1)
Elbow, coolant supply, 90° M18x1.5 to 3/4 hose bead (5015873)	1	(2)
Elbow, air inlet M27x2 to #16 (5015874)	1	(3)
Elbow, 90° air discharge M22x1.5 to #12 JIC (5015875)	1	(4a)
Adapter, #12 to #16 for discharge line (5015876)	1	(4b)
Tube, formed inlet with #16 flare & nut (5015884)	1	(5)
Tee, compressor oil inlet (supplies oil to 50DN) (5015878)	1	(6)

Kit Pc. No. 5016661
Coolant Supply and Return Contents:

Description	Quantity	Key
1/2" NPT plug (239568)	1	(7)
Hose clamps for 3/4 reinforced heater hose (5015883)	2	(8a)
3/4" NPT male thread, 3/4" NPT female, 45° elbow (5015879)	1	(8b)
3/4" NPT male thread, 3/4" hose bead, 45° elbow (5015880)	1	(8c)
3/4" ID reinforced silicone coolant hose (5015881)	.5 ft (not shown)	
7/16" Hardened washer (Grade 8), 1/8" thick (5015882)	1	(9)

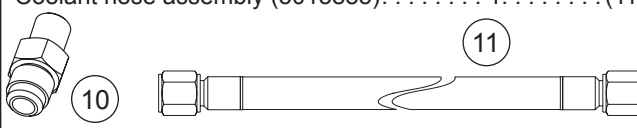

Kit Pc. No. 5016662
For CNG only Installations.
Contents:

Description	Quantity	Key
3/8" NPT to #8 JIC adapter (5004105)	1	(10)
Coolant hose assembly (5015885)	1	(11)



Kit Pc. No. 5016663
Rear Support Bracket for the Replacement Compressor.
Contents:

Description	Quantity	Key
Support Bracket (5011680)	1	(12)
Bolt, M10 (5007856)	4	Not shown

Kit Pc. No. 5016664
For Diesel Only Installations.
Contents:

Description	Quantity	Key
M16 to #8 SAE adapter (5016020)	2	(13)
#8 SAE to #10 SAE adapter (5016135)*	1	(14)
#8 SAE to #6 SAE adapter (5016520)*	1	(15)
#8 SAE to #8 SAE 90° swivel (5016137)	2	(16)
*Includes copper gasket for #8 adapter	1	(17)

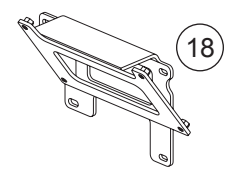

Kit Pc. No. 5016250
ECM Relocation Kit.

Description	Quantity	Key
ECM Mounting Bracket (5016021)	1	(18)
Bolt, M8 ECM bracket (5015754)	3	not shown
Bolt, M10 Support bracket (5007856)	1	not shown

GENERAL SAFETY GUIDELINES



WARNING! PLEASE READ AND FOLLOW THESE INSTRUCTIONS

TO AVOID PERSONAL INJURY OR DEATH:

When working on or around a vehicle, the following guidelines should be observed AT ALL TIMES:

- ▲ Park the vehicle on a level surface, apply the parking brakes and always block the wheels. Always wear personal protection equipment.
- ▲ Stop the engine and remove the ignition key when working under or around the vehicle. When working in the engine compartment, the engine should be shut off and the ignition key should be removed. Where circumstances require that the engine be in operation, **EXTREME CAUTION** should be used to prevent personal injury resulting from contact with moving, rotating, leaking, heated or electrically-charged components.
- ▲ Do not attempt to install, remove, disassemble or assemble a component until you have read, and thoroughly understand, the recommended procedures. Use only the proper tools and observe all precautions pertaining to use of those tools.
- ▲ If the work is being performed on the vehicle's air brake system, or any auxiliary pressurized air systems, make certain to drain the air pressure from all reservoirs before beginning ANY work on the vehicle. If the vehicle is equipped with a Bendix® AD-IS® air dryer system, a Bendix® DRM™ dryer reservoir module, or a Bendix® AD-9si® air dryer, be sure to drain the purge reservoir.
- ▲ Following the vehicle manufacturer's recommended procedures, deactivate the electrical system in a manner that safely removes all electrical power from the vehicle.
- ▲ Never exceed manufacturer's recommended pressures.
- ▲ Never connect or disconnect a hose or line containing pressure; it may whip and/or cause hazardous airborne dust and dirt particles. Wear eye protection. Slowly open connections with care, and verify that no pressure is present. Never remove a component or plug unless you are certain all system pressure has been depleted.
- ▲ Use only genuine Bendix® brand replacement parts, components and kits. Replacement hardware, tubing, hose, fittings, wiring, etc. must be of equivalent size, type and strength as original equipment and be designed specifically for such applications and systems.
- ▲ Components with stripped threads or damaged parts should be replaced rather than repaired. Do not attempt repairs requiring machining or welding unless specifically stated and approved by the vehicle and component manufacturer.
- ▲ Prior to returning the vehicle to service, make certain all components and systems are restored to their proper operating condition.
- ▲ For vehicles with Automatic Traction Control (ATC), the ATC function must be disabled (ATC indicator lamp should be ON) prior to performing any vehicle maintenance where one or more wheels on a drive axle are lifted off the ground and moving.
- ▲ The power **MUST** be temporarily disconnected from the radar sensor whenever any tests **USING A DYNAMOMETER** are conducted on a vehicle equipped with a Bendix® Wingman® system.
- ▲ You should consult the vehicle manufacturer's operating and service manuals, and any related literature, in conjunction with the Guidelines above.

INTRODUCTION

These instructions cover the replacement of Bendix® Tu-Flo® 750 and DuraFlo 596™ compressor on DDC® S50 and S60 engines using Diesel or Compressed Natural Gas (LNG or CNG). Since individual vehicles may have variations of installation, use these instructions as a general guide, using your experience to guide you in any adjustments needed for the particular vehicle.

Read and understand these instructions before beginning work on the vehicle.

Where necessary, you may speak to a Bendix Service Engineer (see the Contacts area on bendix.com for a directory), or call the Bendix Tech Team at 1-800-AIR-BRAKE (1-800-247-2725), option 2.

SECTION 1: (ALL VEHICLES) REMOVAL AND VEHICLE PREPARATION:

DISASSEMBLY

1. Follow all the General Safety Guidelines on this page.
2. Drain the air system.
3. Drain the engine coolant.
4. Remove the alternator and alternator bracket. Retain the mounting hardware.

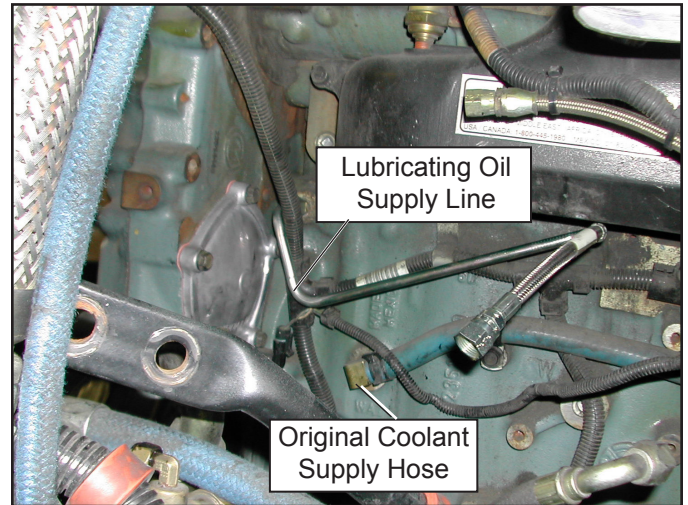

Figure 1 – Engine Compartment After Compressor Removal

5. Disconnect the air inlet and delivery fittings from the compressor.
6. Disconnect the lubricating oil inlet and delivery (where applicable) from the compressor.
7. **Series 50 CNG and LNG applications:** The upper hole of the rear support bracket for the Tu-Flo 750 compressor has a stud which provides a mounting point for the Knock Sensor. Remove the Knock Sensor and retain for reuse in Step 22 of Installation. Discard the stud.
8. Remove the compressor and its rear support bracket. Retain the mounting hardware.

INSTALLATION

NOTE: To show clearer views, some of the photos shown in these instructions feature an engine that has been removed from the bus.

1. Clean the engine (where necessary) to remove all road grime etc. from the installation area.
2. Since the new compressor is larger than the original, it is necessary to prepare the lubrication oil supply line for the new installation by carefully adjusting the angle of the bend from approximately 90° to approximately 150°. (See Figure 1). This will allow the original line to be reused for the new installation. If the line is damaged, cracked, etc. replace it.

3. **SERIES 50 ENGINES:** Disconnect the original coolant supply hose (See Figure 1) and fitting from the engine block. The pipe plug (7), is then installed into the engine block. Since the Bendix® BA-922® compressor requires a higher pressure source of coolant to operate, the installation requires the routing of a new coolant line from the engine oil cooler housing.

SERIES 60 ENGINES: The coolant source is at a sufficient pressure, so the original coolant line may be re-used.

4. **FOR DIESEL ENGINES WITH A SIDE-MOUNT ELECTRONIC COMMUTATED MOTOR (ECM):** Since the replacement compressor is slightly longer than the original, a bracket is used to adjust the ECM unit's position. Before removing the harnesses, mark as necessary to aid in the reinstallation. Unplug the harnesses on the front and back side of the ECM (Engine Sensor Harness, Vehicle Interface Harness, Communication Harness, Injector Harness and Power Harness). Unbolt and remove the ECM from the engine. Retain the ECM mounting bolts and isolators. Remove the ECM stand-off studs. The ECM and bracket will be installed after the compressor installation (see Step 16).
5. **FOR CNG ENGINES:** Check that the coolant return line that runs around the front of the engine to the water pump inlet is the original hard steel. If the coolant return has been replaced by a flexible line, it is necessary to return the line to the original specifications using DDC® p/n 23528004, or its direct replacement.

FOR ALL DIESEL ENGINES: Check that the coolant return line is a hard line that runs from the air compressor, around the front of the engine, to the water pump inlet. This hard line is DDC p/n 23530765 when the original compressor was a Bendix® DuraFlo 596™ compressor and p/n 23526867 for Bendix® Tu-Flo® 750 compressors. If the coolant return has been replaced by a flexible line, it is necessary to return the line to the original specifications. Either of these part numbers can be used with the BA-922 compressor.

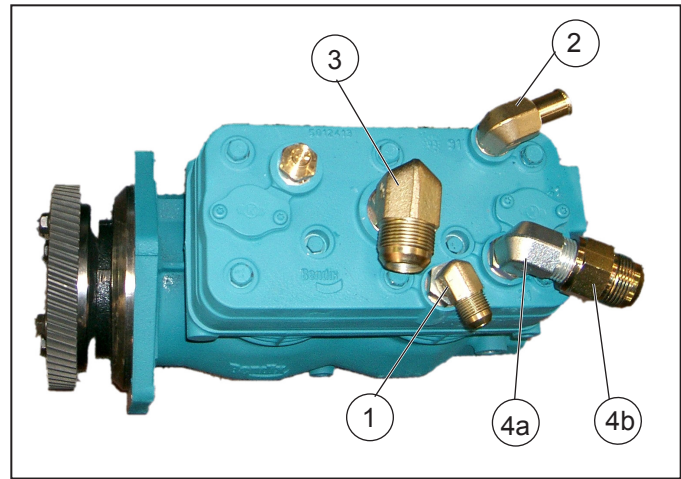

Figure 2 – Compressor Preparation

PREPARE THE REPLACEMENT COMPRESSOR (SEE FIGURE 2)

NOTE: The coolant and air inlet fittings (2) and (3) below must be installed before installing the compressor on the vehicle because the engine intake manifold will prevent sufficient access to the ports.

6. Install the coolant inlet fitting (2) – a 90° M18 to 3/4" hose bead adapter) with final orientation towards the rear of the compressor.
7. Install the compressor air inlet fitting (3) – a 90° M27 to #16 JIC adapter) as shown in Figure 2. It is installed oriented to the left side of the compressor.
8. Install the compressor coolant outlet fitting (1) – a 90° M18 to #8 JIC adapter). It is oriented to the left side - see Figure 2.
9. Install the compressor air discharge fitting (4a) – a 90° M22 to #12 JIC adapter). It is generally oriented toward the rear left corner of the compressor. Bendix recommends that all installations use a size #16 discharge hose size and the kit includes a #12 to #16 JIC adapter (4b) for this purpose. A #12 discharge line may be permitted in some cases, depending on the length and/or restriction of the discharge piping. **NOTE:** If using a #12 discharge line, the compressor performance should be monitored and the discharge line should be upgraded at the first sign of any restricted compressor discharge line symptoms (such as oil passing, high operating temperatures, etc.).
10. After the fittings have been installed, prepare the compressor and engine compartment as follows: Use a suitable adhesive to fasten the compressor gasket (DDC p/n 8929299) to the engine gear case.
11. To assist mounting the compressor, a stud, installed in the top compressor mounting hole of the engine gear case, is used to help support and guide the compressor into position.

When replacing a Tu-Flo 750 compressor, inspect the original stud and if it is not in good condition, replace it using DDC p/n 23517130.

When replacing a DuraFlo 596 compressor (which typically do not have the stud present) remove the compressor adapter and install a stud using DDC p/n 23517130.

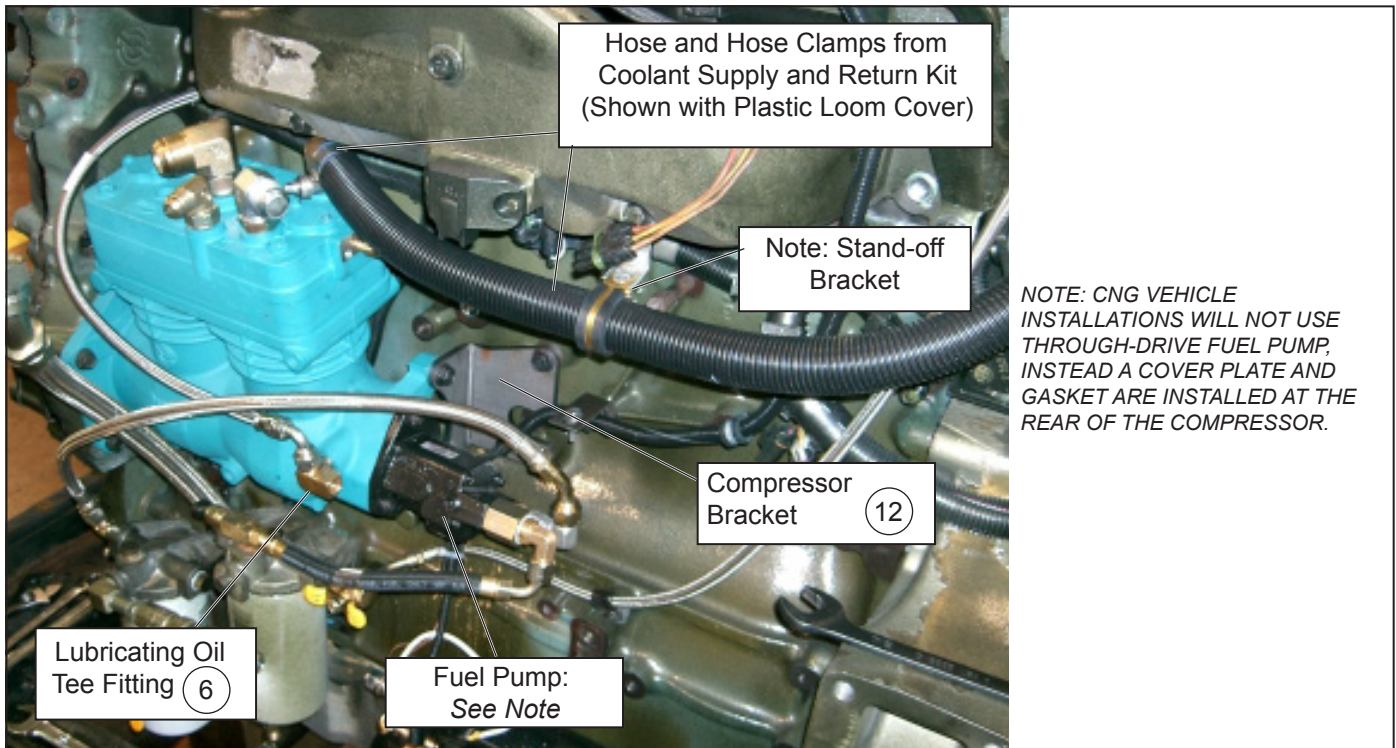

Figure 3 – Shows Mounting Bracket, Coolant Supply Routing, and Fuel Pump

12. Also, prepare the engine compartment by temporarily disconnecting the Detroit Diesel Electronic Control Timing Reference Sensor (DDEC TRS) sensor wiring, to avoid pinching the wires between the flanges during installation. Temporarily secure the wiring safely out of the way.

COMPRESSOR INSTALLATION

13. Because of the size and weight of the compressor, and the fact that during installation the drive gear on the compressor has to align with the vehicle gear train, for ease of installation, we recommend that the technician orient the compressor pistons at mid-stroke so that the drive gear is easier to turn by hand. The technician may also need to temporarily remove the hydraulic pump and drive coupling to assist in the compressor installation. Follow the vehicle manufacturer's recommendation when reinstalling the hydraulic pump and drive coupling. *See page 1 for potential hydraulic pump flange gasket part numbers.*

To ensure that the installed fittings can clear the intake manifold, orient the compressor with the top leaning away from the engine as it is brought into position. Once clear of the manifold, rotate the compressor to an upright position and align it so that the stud inserts in the top mounting hole.

14. Inspect the flange bolts removed during disassembly and reuse if in good condition. Torque to 43-54 ft-lbs (58-73 Nm).

See Figure 3 for a typical installation.

15. Install the compressor rear support bracket (12), mounting it first to the compressor and then to the engine block using the four M10-1.5 bolts included in the bracket kit. Torque to 43-54 ft-lbs (58-73 Nm).

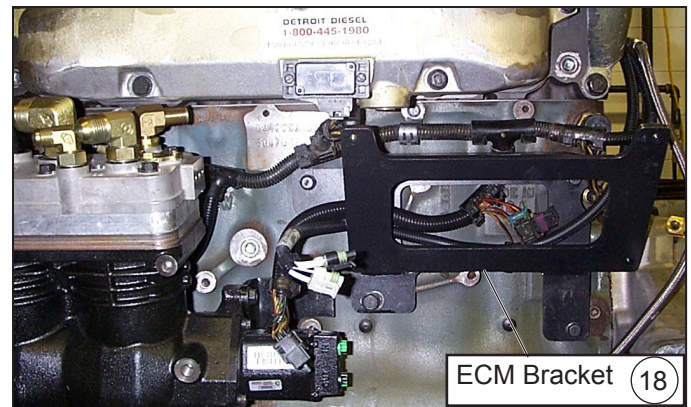

Figure 4 – ECM Mounting Bracket

16. **FOR DIESEL ENGINES WITH SIDE-MOUNT ELECTRONIC COMMUTATED MOTOR (ECM):** Install the ECM relocation bracket (18) directly to the engine block. The top two mounting holes of the bracket install in the same location as the original ECM bolts. Torque the M8 bolts to 23-27 Nm (17-20 ft-lbs) and torque the M10 bolt to 58-73 Nm (43-54 ft-lbs). The installer can choose, depending on the particular vehicle arrangement, to install the ECM unit at this time or after the compressor installation is complete, but the bracket must be installed before continuing with the retrofit.

ECM Re-Installation. Route the engine sensor harness and injector harnesses through the center of the bracket, behind the ECM. In some cases, the clips securing the harnesses to the engine may have to be loosened to adjust the harness positions, however, the harness loom should never require cutting.

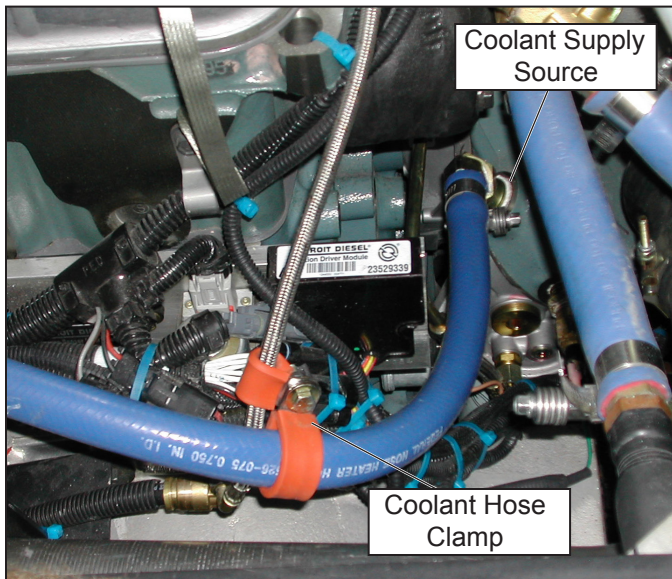

Figure 5 – Coolant Routing at the Engine Cooler Housing

Install the ECM on to the bracket using the original fasteners and isolators. Reinstall the harness connectors, and check the installation to be sure that no parts of the harness touch the edges of the bracket or are chaffing against any part of the engine. Where necessary re-adjust the harness and use appropriate measures to prevent damage.

17. Install the Lubricating Oil Tee Fitting (6) into the compressor. (See Figure 2). Connect the lubrication oil supply line that was adjusted in Installation Step 2 on page 4 to the vertical leg of the tee fitting (6). Typically, the lubrication oil supply hose leading to the alternator connects to the third port of the tee fitting. In installations where an oil cooled alternator is not used, plug the unused tee fitting port.

18. **DIESEL ENGINES ONLY:** The Bendix® BA-922® compressor requires a new fuel pump because the replacement compressor through-drive uses a spline drive, while the previous compressor used a coupling drive.

See the list on Page 1 for the fuel pump, o-ring and fuel line part numbers. The Diesel Fittings Kit (5016664) includes fittings that are potentially needed to adapt to the existing fuel arrangement. Since the location or arrangement of the primary and secondary fuel filters vary, the technician will need to use the fittings (or a combination of these fittings) to adapt to most fuel arrangements. Not all the fittings included in the kit will be used. Refer to the engine manufacturer's requirements for fuel pump installation (at the time of publication, Detroit Diesel® application requirements stated that the maximum allowable fuel inlet restriction for a clean fuel filter was 6.0" of Hg and 12" of Hg for a dirty filter).

19. The 3/4" I.D. silicone coolant supply hose supplied in kit 5016661 connects to the coolant inlet fitting on the compressor. See Figure 3. The hose is routed from the compressor fitting, around the rear of the engine to the engine oil cooler housing. Fasten the hose using the

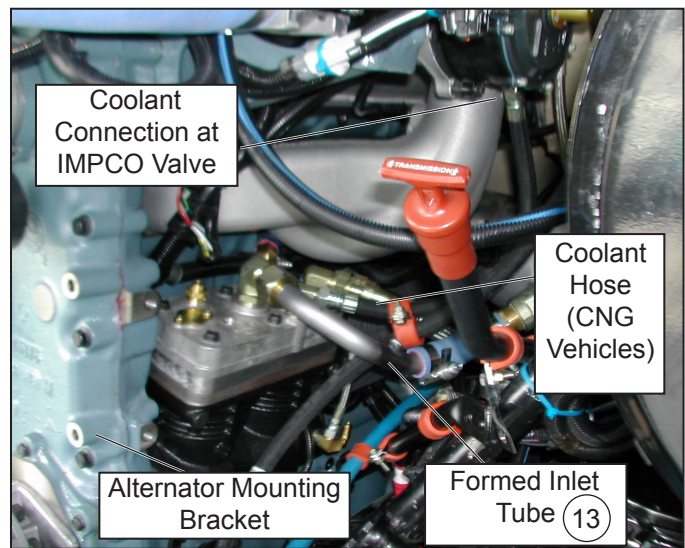

Figure 6 – Engine Compartment View (CNG)

supplied constant tension hose clamps. The hose is to be wrapped in a plastic loom and clamped as necessary to avoid chaffing and/or contact with moving or high-temperature engine parts.

20. See Figure 5. For a typical installation, the silicone hose connects to a 3/4" hose bead to 3/4" NPT 45° adapter which in turn connects to a 3/4" to 3/4" NPT 45° adapter. The adapter is installed in one of three available ports on the cooler housing. Depending on the vehicle, the current use of oil cooler housing ports for the cab heater or temperature sending unit may need to be re-assigned in order to accommodate the air compressor coolant fittings. In most installations, both 45° fittings are required to provide sufficient clearance around the engine.

It is important to avoid any possibility of chaffing or pinch points when routing the coolant hose around the engine. Figure 4 shows a typical arrangement where the coolant hose is secured as necessary. Be sure to consider the clearances required around any vehicle components that may be mounted to the rear of the engine when deciding on the best routing. Stand-off brackets and P-clamps may be required.

21. When installing the coolant return lines, use any stand-off brackets etc., necessary to maintain clearances from engine components.

For CNG ENGINES: Install the included a 3/8" NPT to #8 JIC adapter fitting (10), at the IMPCO valve (See Figure 6). The other end of the hose connects to the compressor coolant outlet fitting (1) (See Figure 1). The included hose is an 18 inch long assembly with #8 JIC fittings on both ends.

For DIESEL ENGINES: Install the coolant return line (DDC p/n 23526867) from the air compressor, Fitting (1), (See Figure 1), around the front of the engine, to the water pump inlet. Figure 7 shows a typical coolant return line that runs from the air compressor, around the front of the engine, to the water pump inlet.

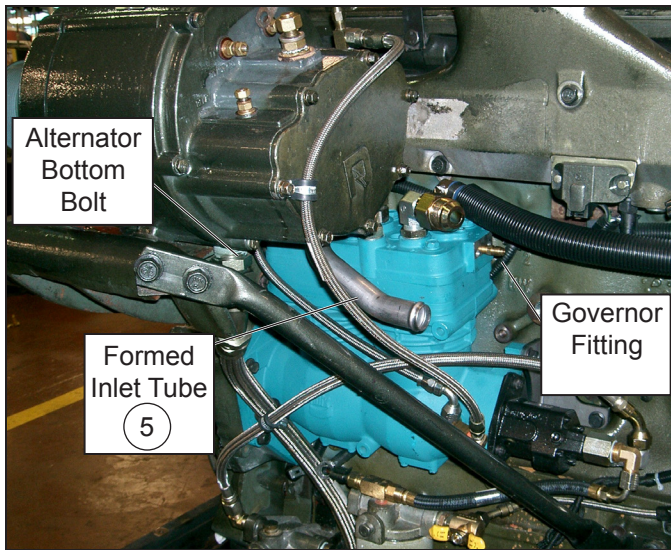

Figure 7 – Engine Compartment View

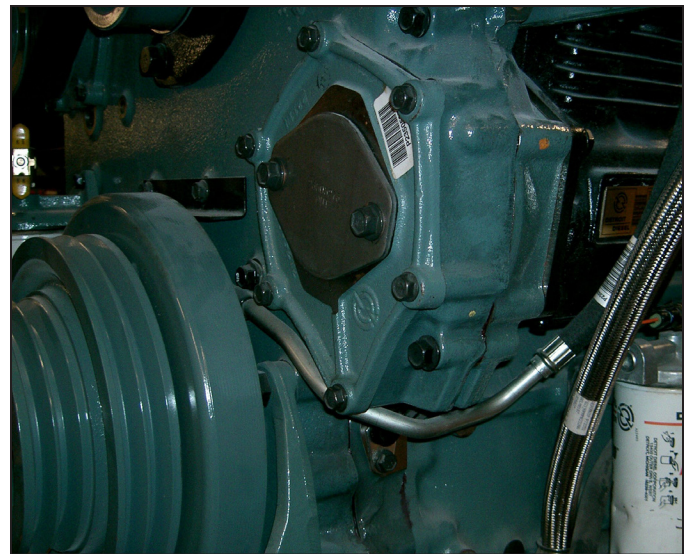

Figure 8 – Coolant Routing (Diesel Engines)

22. **For CNG ENGINES:** The new rear support bracket uses mounting holes on the block further away from the front of the engine. Install the knock sensor, removed during step 7 of Disassembly, into the upper mounting hole that was previously used by the original rear support. The stud is not required. Care should be taken not to over-tighten the assembly because of the potential to crack the sensor body. Use a 7/8" crows-foot adapter to tighten the sensor mounting bolt.

23. Install the 1.0" OD Formed Air Inlet Tube (5) onto the compressor inlet fitting (3). See Figure 6 for orientation. The inlet hose connects to the #16 elbow (shown in Figure 3 as (3)). Select a hydrocarbon-resistant inlet hose of 1.0" ID. Use a reinforced hose capable of withstanding 400°F temperatures and of a material strong enough to resist kinking and will not collapse under the forces present at the compressor inlet.

24. **ALTERNATOR RE-INSTALLATION.**

See Figure 6 for the location of the bottom bolt in the alternator mounting bracket (*NOTE: In many cases, this bolt is originally painted green*). **The 7/16" diameter, 1/8" thick hardened washer, included in the kit, must be placed under the head of the bolt** in order to avoid interference between the BA-922® cylinder head and the end of the alternator mounting bolt. Follow the vehicle manufacturer's guidelines for torque spec's.

25. **GOVERNOR RE-INSTALLATION.** In most cases, the governor is remotely mounted. Install a 1/8" NPT fitting at the compressor governor port and route the line to the governor. If the governor is to be mounted directly to the compressor then the Bendix gasket p/n 236577 and two M8 – 2.95 (75mm) bolts are required.

See Figure 6 for a typical final compressor installation.

OPERATION AND LEAKAGE TEST

LEAKAGE TEST

Run engine and inspect for any leakage at the coolant or lubricating oil fittings. Repair as necessary.

With the engine running, lower air system pressure to 60 psi and apply a soap solution around the cylinder head. Air fittings are permitted leakage of a one inch bubble in one minute.

Check the gasket between the cylinder head and the valve plate assembly and the reed valve/gasket between the valve plate assembly and cylinder block for air leakage. No air leakage is permitted at the cylinder head gaskets. If leakage is detected, replace or repair the compressor.

OPERATION TEST

1. With service and supply system leakage below the maximum allowable limits and the vehicle parked, bring the system pressure to governor cut-out and allow the engine to idle.
2. The compressor should remain unloaded for a minimum of 5-10 minutes. If compressor cycling occurs more frequently and service and supply system leakage is within tolerance, replace the compressor or repair the compressor unloader system using a genuine Bendix maintenance kit available from authorized Bendix parts outlets.

After installation, Bendix recommends that the technician use BW-121A, available from the Bendix Tech Team 1-800-AIR-BRAKE (1-800-247-2725), option 2 or e-mail to: techteam@bendix.com as a full "Installation and Application Review".



Knowledge Dock™
Please select media to browse.

Blog Video Blog Tech Tips Podcast

Trucking moves fast. Move faster.
Knowledge Dock™
• BLOGS • PODCASTS • VIDEOS • 24/7/365
[knowledge-dock.com]



Log-on and Learn from the Best
On-line training that's available when you are – 24/7/365.
Visit brake-school.com.